

64

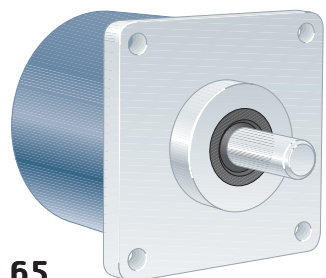

65

## Short description:

- >> 6 short-circuit protected outputs
- >> IP 67 at housing, IP 66 at shaft inlet
- >> 5 Vdc or 9...30 Vdc
- >> Robust housing for harsh environment
- >> Shock and vibration protected
- >> Imperial measurements 2,5" flanges and 3/8" shaft

## Suitable applications:

- >> Standard to demanding industrial applications

## General information

Encoder data		
Type	RSI 505	
Operating temperature	-40°C .. +70°C	
Storage temperature	-30°C .. +70°C	
Ingress protection class	IP-67 according to IEC 60529	
At shaft inlet	IP-66 according to IEC 60529	
Vibration (55 to 2000Hz)	< 300 m/s <sup>2</sup> according to IEC 60068-2-6 <sup>(1)</sup>	
Shock (6ms)	< 2000 m/s <sup>2</sup> according to IEC 60068-2-27	
Cover material	Aluminium	
Cover surface treatment	Coated and cromated or anodized	
Weight	Approx. 300g	
Accuracy and resolution		
Line count	1..5000 ppr	5001..10 000 ppr
Dividing error	± 50 °el	± 90 °el
Channel separation	90 ± 25 °el	90 ± 45 °el
Measuring steps	4 x Line count	

## Flange option

Flange type	64, Round	65, Square
Outer geometry	ø2,5" (63.5mm)	2,5" (63.5mm)
Mounting holes	3 x UNF 10x32 4 x UNC 4x40	4 x 5.2mm
Flange material	Aluminium	Aluminium
Surface treatment	Anodized	Anodized

## Shaft option

Shaft type	Ø8 round	Ø3/8" (9.52) round	Ø10 with face
Axial shaft load	50 N	50 N	50 N
Radial shaft load	60 N	60 N	60 N
Mech. permissible speed	6000 rpm (12 000)	6000 rpm (12 000)	6000 rpm (12 000)
Shaft material	Stainless steel	Stainless steel	Stainless steel
Moment of inertia	1,9 x 10 <sup>-6</sup> kgm <sup>2</sup>	1,9 x 10 <sup>-6</sup> kgm <sup>2</sup>	2,0 x 10 <sup>-6</sup> kgm <sup>2</sup>

<sup>(1)</sup><150m/s<sup>2</sup> on encoders with connectors

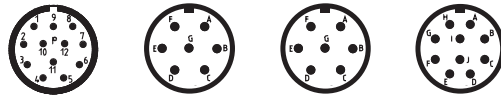

### Connection option

Connector type	Cable	12 pin EML	7 pin MS	7 pin MS sp	10 pin MS
Function	Colour	PIN	PIN	PIN	PIN
S00	Green	5	A	A	A
S00 inverted	Blue	6	NA	C	G
S90	Yellow	8	B	B	B
S90 inverted	Black	1	NA	E	H
Sref	Red	3	C	NA	C
Sref inverted	Brown	4	NA	NA	I
+E Volt	Violet	12	D	D	D
0 Volt	White	10	F	F	F
STATUS	Gray	7	NA	NA	NA
Sensor +E Volt	NA	NA	NA	NA	E
Case	Shield	Chassis	Chassis	Chassis	Chassis

### Electrical option

Power supply	5 V ±10%	9-30 V	
Polarity protected	No	Yes	
Output signals	TTL <sup>1</sup>	HTL	RS-422
Short circuit protected	Yes	Yes	Yes
Current consumption	45 mA	50 mA at 24Vdc	25 mA at 24Vdc
Max consumption	75 mA	75 mA	40 mA
Output load (max)	±20 mA	±40 mA	±20 mA
Output frequency (max)	300 kHz	300 kHz	300 kHz
U <sub>high</sub> at 10mA load	> 3.0 V	> +EV - 2.0 V	> 3.0 V
U <sub>low</sub> at 10mA load	< 0.4 V	< 1.15 V	< 0.4 V
Cable length (max)	50 m	200 m @ 50 kHz	1 km (TIA/EIA-422-B)
STATUS output	Yes	Yes	Yes
High level	Encoder OK	Encoder OK	Encoder OK
Low level	Warning/Failure	Warning/Failure	Warning/Failure

<sup>1</sup>TTL output comply to the RS-422 standard when differential transmission is used NA=Not Available

### Output circuit

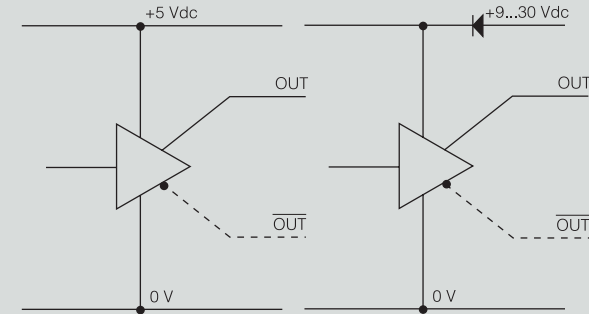

### Output signals

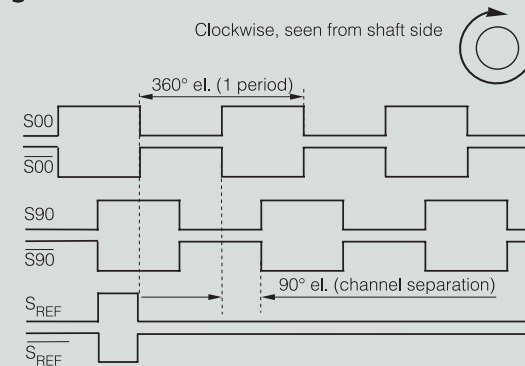

### Status outputs

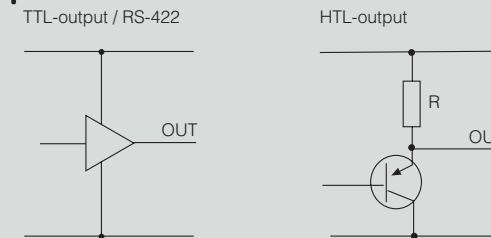

## Dimensions

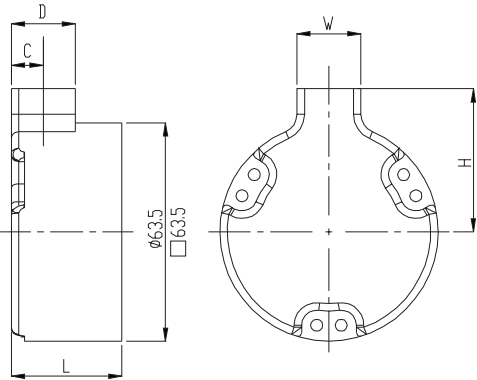

Connector	Orientation	L	H	W	D	C
Cable	Radial	29.4	34	17	17	8.5
	Axial	38.9	-	-	-	-
EML	Radial	29.4	32	27	27	13.5
	Axial	38.9	-	-	-	-
MS 7p	Radial	-	-	-	-	-
	Axial	38.9	-	-	-	-
MS 10p	Radial	-	-	-	-	-
	Axial	43.9	-	-	-	-

## Flanges

### 64, round

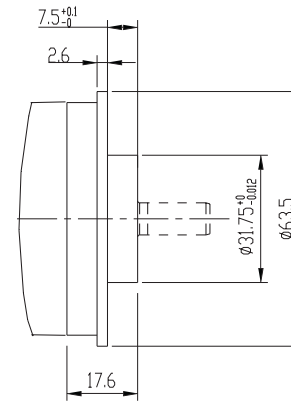
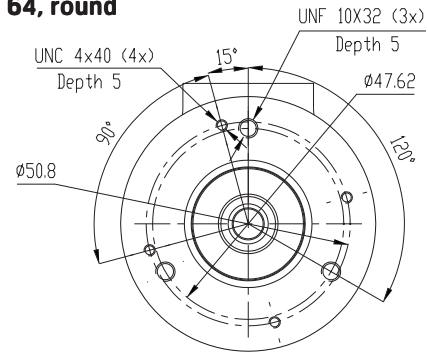

### 65, square

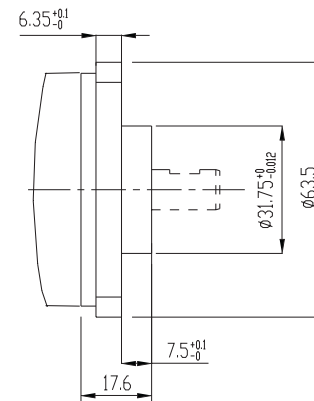
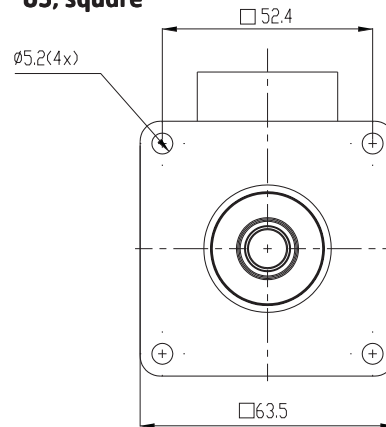

## Connectors

### Cable 5x2x0,25 shielded

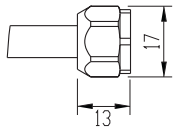

### 12pin EML

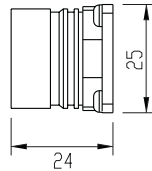

### 7pin MS

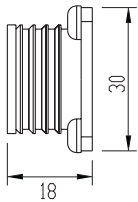

### 7pin MS sp

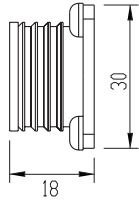

### 10pin MS

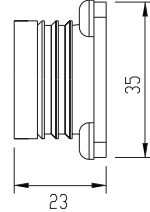

## Shafts

### 8 mm round

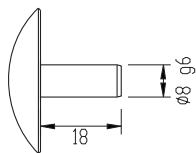

### 3/8" (9.52 mm) round 10 mm with face

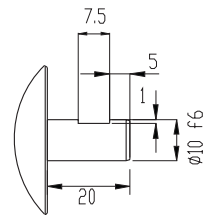
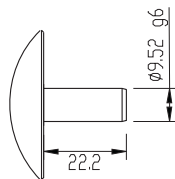

## Various combinations/examples

### RSI 505 64

8 mm round, radial MS

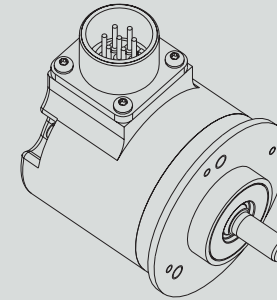

### RSI 505 65

10 mm with face, radial MS

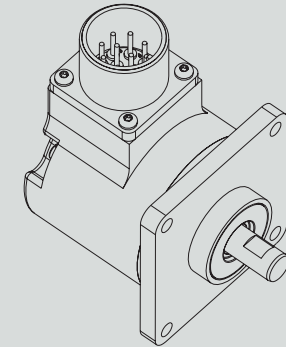

## Ordering information Tick your choice

Type	RSI 505					
Flange	64, Round	65, Square				
Shaft	Ø8 round	Ø9.52 round	Ø10 with face			
Electronics <sup>(1)</sup>	Supply	5Vdc		9-30Vdc		
	Output	TTL	HTL	RS-422		
Connection	Cable	12 pin EML	7 pin MS	7 pin MS sp	10 pin MS	
Connecting direction	Axial/Radial	Axial/Radial	Axial/Radial	Axial/Radial	Axial/Radial	
Line count	1..5000	5001..10 000				

<sup>(1)</sup> Possible combinations: 5Vdc/TTL, 9-30Vdc/HTL or 9-30Vdc/RS-422

**Please, specify line count and cable length when ordering**

Ordering example: RSI 505 65 Ø8ro 5Vdc 1024ppr TTL 12 pin EML Axial